

NO.	DATE	REVISION RECORDS	REVISED	REVISION NO.
—	21/FEB/2017	PROTOTYPE	K.SAKAI	—
△	21/JUN/2017	TERMINAL SHAPE CHANGE, etc	H.ISHINAGA	—
△	07/NOV/2017	ADD PARTS NUMBER	K.SAKAI	—

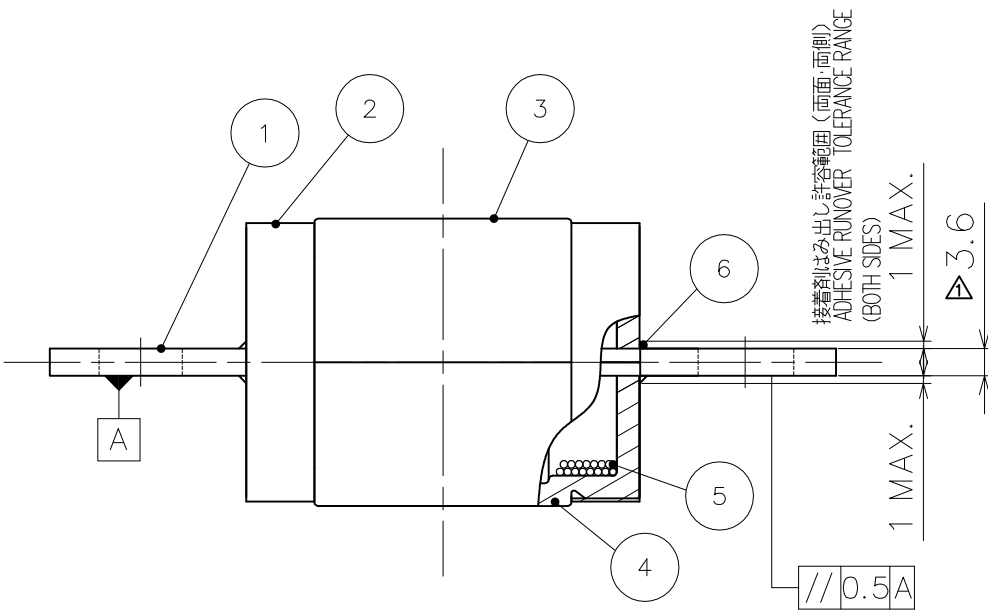
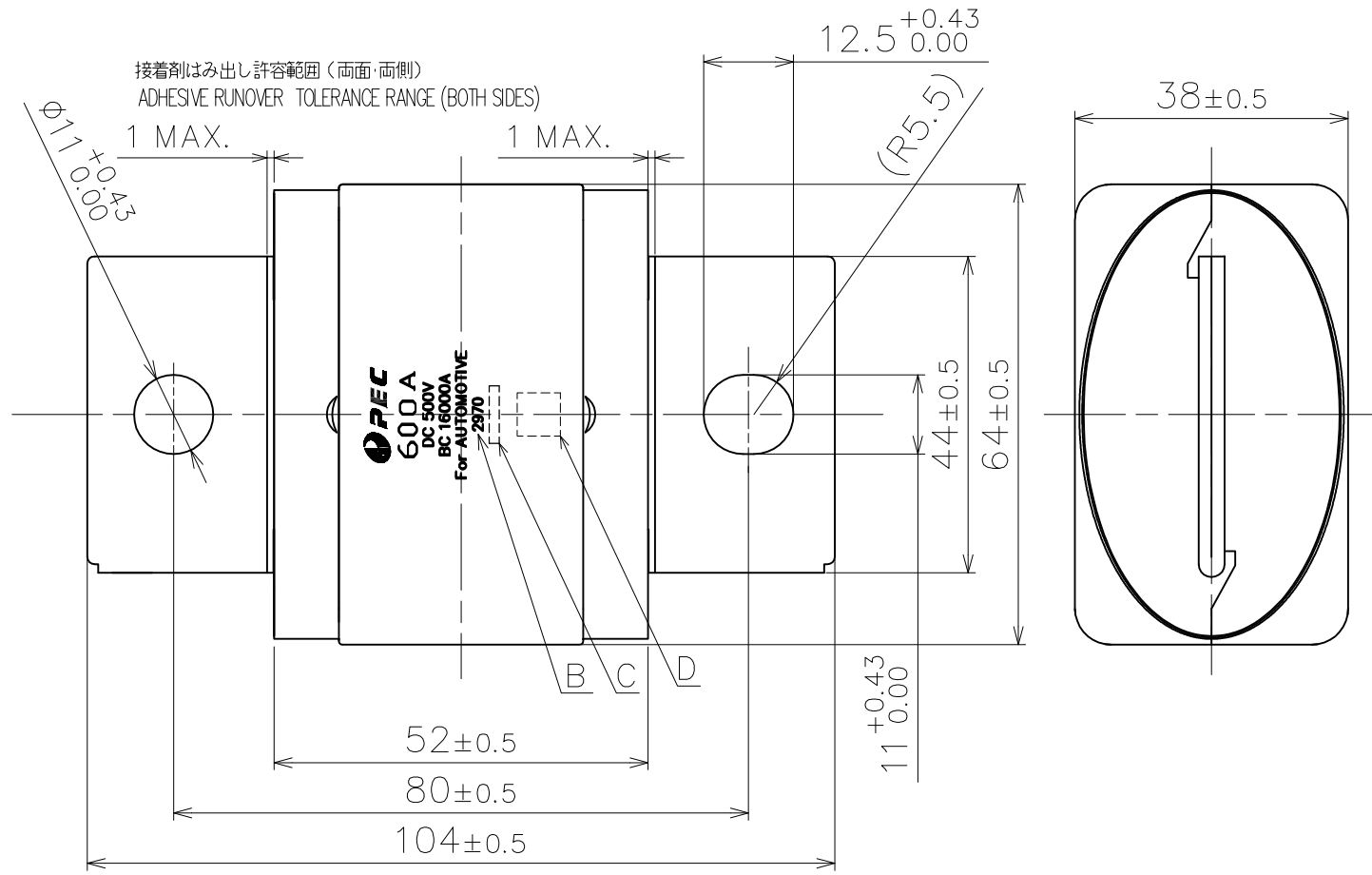

仕様

- 1.定格電圧 : 500VDC △
- 2.定格遮断容量 : 16000A
- 3.使用温度範囲 : -40℃~100℃ △
- 4.保管温度範囲 : -40℃~100℃ △
- 5.ヒューズ性能 : 太平洋精工規格PES-A52-079に準ずる。
- 6.ヒューズの固定方法 : M10ボルト2本で固定。
- 7.PES-02-04の環境負荷物質の使用禁止・制限規定を遵守する事。

RATED CURRENT	PART NO.
500A	29750000 △
600A	29700000
700A	29710000
800A	29720000
900A	29730000
1000A	29740000

SPECIFICATIONS

- 1.RATED VOLTAGE : 500VDC △
- 2.BREAKING CAPACITY : 16000A
- 3.OPERATING TEMPERATURE LIMIT : -40℃...100℃ △
- 4.STORAGE TEMPERATURE LIMIT : -40℃...100℃ △
- 5.FUSE PERFORMANCE : PERFORMANCE OF THIS PART CONFORMS TO PES-A52-079.
- 6.FUSE FIXING METHOD : USE TWO M10 BOLTS.
- 7.COMPLY WITH ENVIRONMENTAL RESTRICTION AND PROHIBITION WHICH PRESCRIBED UNDER "PES-02-04".

注記

1. 左図は600Aヒューズを示す。
2. 表示はレーザーマーカで印字する事。表示は図面の向きで印字する事。
3. "B"部の数字は社内品番を示す。
4. "C"部には当社製造Lot No.を表示する事。
5. "D"部にはデータマトリクスコードを表示する事。データマトリクスコードはECC200・ISO/IEC16022に準じて印字する事。

NOTE

1. THE DRAWING ABOVE SHOWS THE 600A FUSE.
2. THE CAUTION IS MARKED BY LASER MARKER, AND THE DIRECTION OF THE CAUTION REFER TO THE DRAWING.
3. "B" PORTION SHOWS PEC'S PART NUMBER.
4. "C" PORTION SHOWS A PRODUCT LOT NUMBER.
5. "D" PORTION SHOWS A DATA MATRIX CODE(DMC). THE DMC IS MARKED ACCORDING TO ECC200・ISO/IEC16022.

6	—	ADHESIVE	—	EPOXY RESIN	—	—
5	—	ARC-EXTINGUISHING SAND	—	SILICA	—	—
4	—	CASE B	1	UNSATURATED POLYESTER	—	—
3	—	CASE A	1	UNSATURATED POLYESTER	—	—
2	—	RING	2	COPPER	—	—
1	—	ELEMENT	1	COPPER	—	Sn PLATING
NO.	PART NO.	PART NAME	Q'TY	MATERIAL	SIZE	REMARKS

APPROVED	<i>Moriya</i>	DIMENSION TOLERANCE	ANGULAR TOLERANCE	FINISH
CHECKED	<i>H. Shibata H. Shimizu</i>	±0.2	—	—
DESIGNED	<i>K. Sakai</i>	RUST PREVENTION	MATERIAL	
DRAWN	<i>K. Sakai</i>	—	SEE TABLE	

SCALE	UNIT	DIAGRAM METHOD	PART NAME
1:1	mm	THIRD ANGLE PROJECTION	EVFP-38×64 ***A
DRAWING DATE	DRAWING NAME	3D CAD DATA	PART NO.
07/NOV/2017	G2970-0-2	—	SEE TABLE

Pacific Engineering Corporation

SHEET	SIZE
1 / 1	A3