

MANUAL No. No. PES-A68-019

文 書 名

**S B F C - E S**

REVISION : E

ISSUE DATE : January 18, 2013

FILE No. :

Approved by 

Reviewed by \_\_\_\_\_

Issued by J. Kobayashi



## 1. Scope

This standard specifies SBFC-ES (hereinafter referred to as “fuse links”) used for electrical equipments and circuits of automobiles, with a rated voltage of 32VDC or less.

## 2. Classification

The fuse-links are classified as shown in **Table 1** by their respective rated currents and types.

**Table 1 Classification**

Rated Current A	Part Number	Housing color
50	3354-00*0	Red
60	3364-00*0	Yellow
80	3384-00*0	Black

## 3. Structure

The structure of the fuse-links shall be as follows: a housing comprising an element that is integrated a fusing portion with female terminals for connection.

The fusing portion of the fuse-link shall be visible through the transparent top cover.

## 4. Rated Voltage

The rated voltage of the fuse-links shall be 32VDC or less.

## 5. Quality requirements

The quality requirements for the fuse-links shall be as shown in **Table.2**.

Table 2 Quality requirements

Item		Quality requirement	Measuring device	Measuring method
Appearance		The fuse-links shall be free from defects harmful to use such as flaws, cracks, burr and rust.	Visual inspection	Visual inspection/feeling under the illumination of 300Lx or more
Marking and Housing color		The rated current value, the other markings, and the housing colors shall be clear in order not to misread.		
Visibility of fusing portion		The fusing portion shall be visible clearly through the cover.		Visual inspection from the top cover of the fuse links
Inserting and drawing force of terminal		The force to insert a mating male tab into a female terminal for connection shall be 44.1N or less and the force to draw shall be from 9.8N to 24.5N.	Mechanical force gage	The fuse-links are inserted or drawn into the measuring device as the loads are applied perpendicularly to each terminal of the fuses. (at a constant speed of 50-150mm per min.)
Strength	Cover drawing strength	The drawing strength between the cover and the housing shall be 9.8N or more.		The housing is fixed and the tensile loads are applied to the cover. (at a constant speed of 50-150mm per min.)
	Lance breaking strength	The lance's breaking strength between the element and the housing shall exceed 60N.		The housing is fixed and the loads are applied perpendicularly to each terminal.
	Impact strength	The fuse-links shall be free from defects harmful to use such as terminal deformation, breaks and cracks of housing.		The fuse-links are dropped from the height of 1m on a concrete floor.
	Breaking strength	The breaking strength of the fuse-links shall be 196N or more.		The compressive loads are applied to both the upper and lower ends of the fuse-links.

## 6. Performance requirements

The fuse-links, when tested in accordance with the test methods specified in Clause 7, shall meet the following performance requirements shown in **Table 3**.

**Table 3 Performance requirements**

No	Test item	Performance requirements	Test Method
1	Voltage drop	The voltage drop of fuse-links shall not more than 250 mV.	7.2
2	Transient current cycling durability	The fuse-links shall satisfy the values given in <b>Table 4</b> .	7.3
3	Vibration	The fuse-links shall satisfy the values given in <b>Table 4</b> .	7.4
4	Temperature/humidity	The fuse-links shall satisfy the values given in <b>Table 4</b> and be free from defects harmful to use.	7.5.1
5	Combination accelerated aging test		7.5.2
6	Resistance to oil		7.5.3
7	Resistance to fuel		7.5.4
8	Operating time rating	The fuse-links shall satisfy the values given in <b>Table 4</b> .	7.6
9	Leakage current	The leakage current of fuse-links shall not exceed 0.5 mA.	7.7
10	Breaking capacity	After the test, no continuous arc shall occur, insulators shall not be damaged, a leakage current across terminals shall not more than 0.5 mA, and markings and colors shall not be unclear.	7.8
11	Temperature rise	The temperature rise shall not exceed the values given in <b>Table 5</b> .	7.9
12	Resistance against thermal shock	The fuse-links shall satisfy the values given in <b>Table 4</b> and be free from defects harmful to use.	7.10
13	Temperature coefficient of rated current	The temperature coefficient of the fuse-links' rated current shall not exceed 0.18% per 1°C.	7.11

**Table 4 Operation times**

Test current A	Operating time	
	Minimum	Maximum
110% of rated current	100 h	—
200% of rated current	2 s	60 s
350% of rated current	0.2 s	7 s
600% of rated current	0.04 s	1 s

**Table 5 Temperature rise**

Rated current A	Temperature rise
50—80	45 deg

Temperature rise: the value that subtracted ambient temp. from the measured value.

## 7. Test method

### 7.1 Test conditions

The tests of the fuse-links shall be conducted under the following conditions unless otherwise specified.

- (1) All the electrical tests shall be conducted with a direct current within  $\pm 1\%$  deviation of the specified value supplied at a temperature of  $(23 \pm 5)^\circ\text{C}$ . The fuse-links shall be mounted on the standard test fixture as shown in **Fig. 1**.
- (2) The connecting cables used in the electrical test shall be in accordance with **JIS C 3406** or **JASO D 611**.
- (3) Connecting cable of 600 mm or longer as specified in **Table 6** shall be used for connecting to the fuse-link. When two or more fuse-links are tested in series, each fuse-link shall be mounted at intervals of 150 mm or longer.
- (4) The vibration test, thermal shock test, and environmental exposure test (excluding the combination accelerated aging test in **7.5.2**) shall be conducted without supplying electric current to the fuse-link.
- (5) For those tests other than the vibration test and combination accelerated aging test, the fuse-links shall be positioned vertically.

**Table 6 Connecting cable sizes**

Rated current A	Cross-sectional area (mm <sup>2</sup> )
50	3
60	5
80	8

Fig.1 Standard test fixture

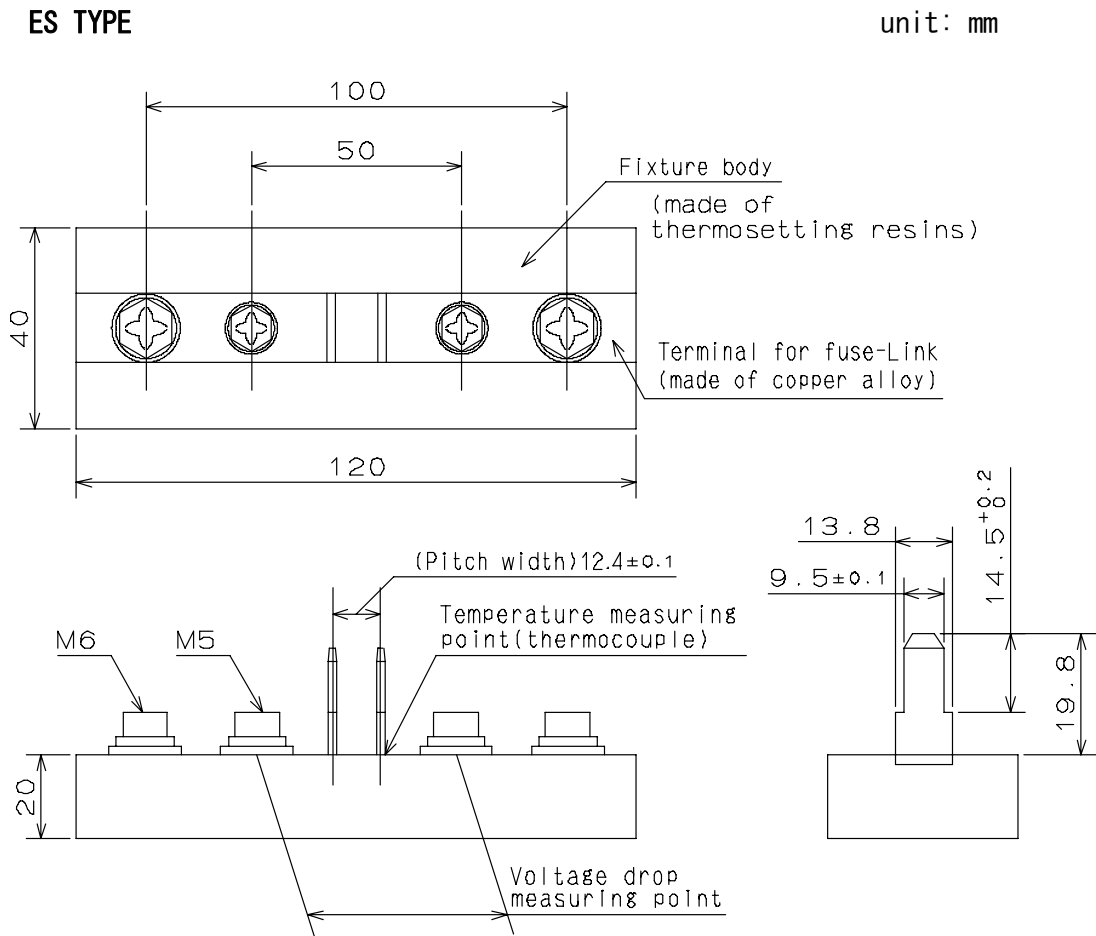

- Remarks**
1. The terminals for fuse-link shall be  $(1.2 \pm 0.05)$ mm in plate thickness according to C2200 of **JIS H 3100**.
  2. The connecting cable shall be clamped to bolts on the both outsides of the fixture in accordance with LA306 or LA406 of **JIS D 5403**.

**7.2 Voltage drop test**

The measurement of the voltage drop (mV) shall be taken at the voltage drop measuring point between the fuse-link terminals as shown in Fig.1 after supplying a current corresponding to a 100% of the rated current for 15 min.

### 7.3 Transient current cycling durability test

After supplying the fuse-link with a transient current corresponding to values ranging from 50 to 200% of the rated current 20,000 times repeatedly in intermittent patterns as shown in Fig. 2, the operating time rating test shall be conducted according to Sub-clause 7.6. The supplied test voltage shall be  $(14 \pm 0.2)$  VDC.

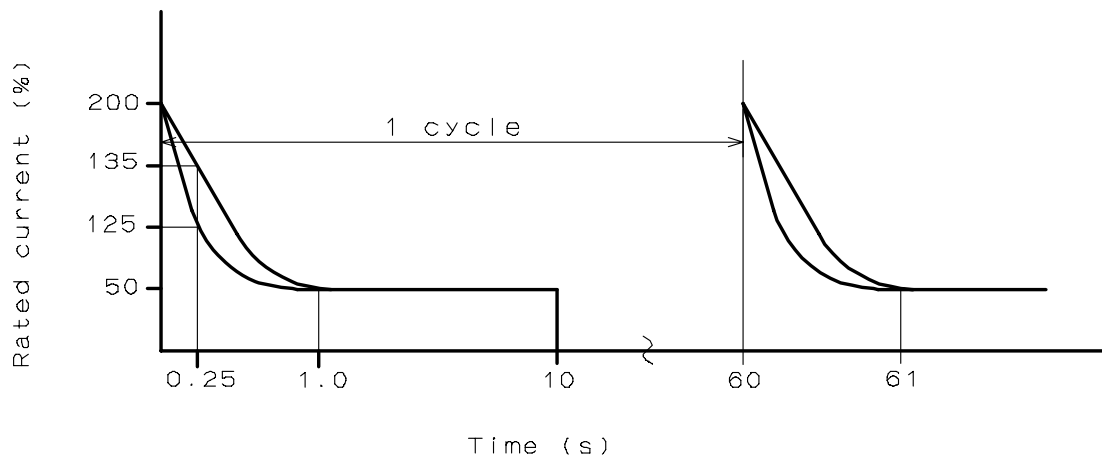

Fig. 2 Transient current cycle

### 7.4 Vibration test

A simple harmonic motion with amplitude of 0.75 mm (1.5 mm from peak to peak) is applied to the fuse-link mounted on the standard test fixture shown in Fig. 1. The applied vibration frequency shall be uniformly varied in a range from 10 to 55 Hz with a cycle procedure to increase from 10 up to 55 Hz, then to return to 10 Hz in about 1 min. The simple harmonic motion shall be applied in three directions cutting each other at right angles for two hours each. After that, the operating time rating test shall be conducted according to Sub-clause 7.6.



## 7.5 Environmental exposure test

### 7.5.1 Temperature/humidity cycling test

A temperature and humidity cycle specified below is applied 15 times repeatedly to the fuse-link, then the operating time rating test according to Sub-clause 7.6 shall be conducted.

- (1) A fuse-link is left for 4 hours in an ambience at the temperature of  $(23\pm 5)^{\circ}\text{C}$  and Relative humidity (45~75)%.
- (2) The temperature and Relative humidity are raised within a half hour to  $(55\pm 2)^{\circ}\text{C}$  and (95~99)%, respectively.
- (3) The fuse-link is left for 10 hours in an ambience at the temperature of  $(55\pm 2)^{\circ}\text{C}$  and Relative humidity (95~99)%.
- (4) The temperature is lowered to  $(-40\pm 2)^{\circ}\text{C}$  in 2 hours and a half.
- (5) The fuse-link is left in an ambience at the temperature of  $(-40\pm 2)^{\circ}\text{C}$  for 2 hours.
- (6) The temperature is raised from  $(-40\pm 2)$  to  $(120\pm 2)^{\circ}\text{C}$  in one and a half hour.
- (7) The fuse-link is left for 2 hours in an ambience at the temperature of  $(120\pm 2)^{\circ}\text{C}$ .
- (8) The temperature is returned to  $(23\pm 5)^{\circ}\text{C}$  in one and a half hour.

The above-described cycle (1) through (8) shall complete at 24 hours.

**Remark:** In the above 24 hours, for the period from (4) to (8), no humidity control is made.

### 7.5.2 Combination accelerated aging test

While applying to the fuse-link at the temperature of  $(80\pm 2)^{\circ}\text{C}$  a simple harmonic motion with a vibration acceleration of  $44.1\text{m/s}^2$ , a vibration frequency 20~200~20Hz, and a sweep time of 3 min, in accordance with JIS D 1601, an electric current cycle as shown in Fig. 3 is applied 300 times repeatedly, then the operating time rating test is conducted according to Sub-clause 7.6. The test voltage shall be  $(14\pm 0.2)\text{VDC}$ .

**Fig. 3 Combination accelerated aging current cycling**

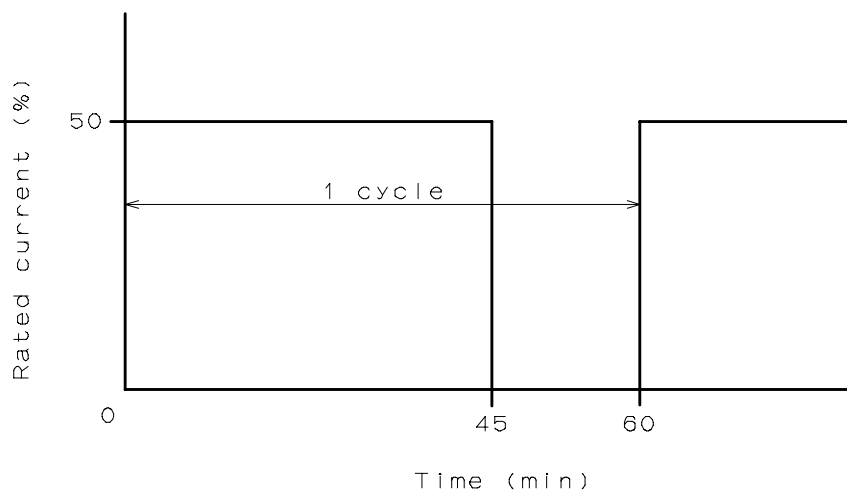

### 7.5.3 Test for resistance to oil

After immersing the fuse-link in No.1 test oil (lubricating oil) in accordance with Sub-clause 5.4.2 of **JIS K 6258** at  $(23\pm 5)^{\circ}\text{C}$  for 1 min, the fuse-link is dried at the temperature of  $(90\pm 2)^{\circ}\text{C}$  for 1 hour, then the operating time rating test shall be conducted according to Sub-clause 7.6.

### 7.5.4 Test for resistance to fuel

After immersing the fuse-link in test oil in accordance with **JIS K 6258** Sub-clause 5.4.1 Category-C (Fuel oil) at  $(23\pm 5)^{\circ}\text{C}$  for 1 min, the fuse-link is dried at the temperature of  $(90\pm 2)^{\circ}\text{C}$  for 1 hour, then the operating time rating test shall be conducted according to Sub-clause 7.6.

## 7.6 Operating time rating test

Prior to the test, both the test fixture and fuse-link shall be stabilized at a temperature of  $(23\pm 5)^{\circ}\text{C}$ . After adjusting the power source to the test current specified in **Table 4**, the fuse-link is supplied with the current and the operating time to blow of the fuse-link is measured.

Especially when testing a number of fuse-links, a sufficient cooling time for the test fixture shall be taken into account to prevent its overheating. The test voltage to be applied shall be  $(14\pm 0.2)\text{VDC}$ .

## 7.7 Leakage current test

The leakage current test shall be conducted as follows.

- (1) A current equal to the fuse-link rating is applied to the fuse-link for 5 min.
- (2) The current is increased in increments of 2.5% of the fuse-link rating per 5 min. until its fusible portion is blow off.

After the fusible portion has been blown off, leakage current at a test voltage of 32VDC of the fuse-link is measured.

### 7.8 Breaking capacity test

A current of  $(1000 \pm 50)$  A is supplied to the fuse-link at a test voltage of  $(32 \pm 2/0)$  VDC with a rise time of  $(2.5 \pm 1.0)$  msec. by the electric circuit as shown in Fig. 4.

The length of 600 mm connecting cables shown in Table 6 shall be connected to the fuse-link.

Fig. 4 Breaking capacity test circuit

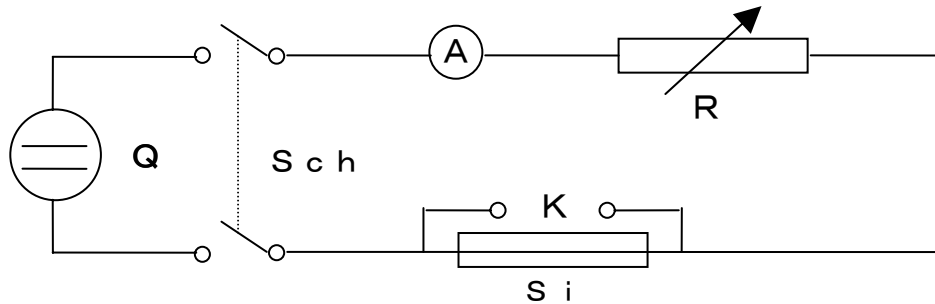

- Where Q : Power source  
 Sch : Switch  
 A : Ammeter  
 R : Adjusting resistor  
 K : Short circuiting switch  
 Si : Fuse

### 7.9 Temperature rise test

The temperature rise (deg) shall be measured at the temperature-rise measuring point at the terminal for fuse-link as shown in Fig. 1 after supplying a current equal to a 50% of the rated current for 40 min.

### 7.10 Thermal shock test

A thermal shock cycle shall be applied 48 times repeatedly to the fuse-link under the following conditions, then the operating time rating test shall be conducted according to Sub-clause 7.6.

- (1) A fuse-link is left in a room at the temperature of  $(-30 \pm 2)$  °C for 30 min.
  - (2) After that, the fuse-link is moved within 15 sec. into a room at the temperature of  $(100 \pm 2)$  °C, where it is left for 30 min.
  - (3) Then, it is brought back within 15 sec. to the room at the temperature of  $(-30 \pm 2)$  °C.
- The above-described cycle (1) through (3) shall complete at 60 min.

### 7.11 Test for temperature coefficient of rated current

The operating time rating tests of the fuse-links are conducted in the ambience of -30, 23, and 70°C, respectively, then the coefficient is calculated by dividing the variation of the rated current by the temperature difference as follows.

$$\sigma = \frac{I_1 - I}{T - T_1} \times \frac{100}{I}$$

$$\sigma = \frac{I - I_2}{T_2 - T} \times \frac{100}{I}$$

- Where  $\sigma$  : Temperature coefficient (%/°C)  
 $T$  : 23°C  
 $T_1$  : -30°C  
 $T_2$  : 70°C  
 $I$  : Rated current (at 23°C)  
 $I_1$  : Varied rated current (at -30°C)  
 $I_2$  : Varied rated current (at 70°C)

**Remark:** Through the operating time rating tests in the ambience of -30 and 70°C, find the respective current values,  $I_1$  and  $I_2$ , to cause the equivalent pre-arcing time-current characteristics to that obtained by  $I$  at 23°C.

### 8. Test sequence

The test sequence of the fuse-links shall be as shown in Table 7.

Table 7 Test sequence

No	Test item	Test Method	Test sample group								
			1	2	3	4	5	6	7	8	9
1	Voltage drop test	7.2	×	×	×						
2	Temperature/humidity cycling test	7.5.1				×					
3	Tests for resistance to oil and fuel	7.5.3 7.5.4					×				
4	Vibration test	7.4						×			
5	Transient current cycling durability test	7.3							×		
6	Combination accelerated aging test	7.5.2								×	
7	Temperature rise test	7.9									×
8	Thermal shock test	7.10									×
9	Leakage current test	7.7			×						
10	Breaking capacity test	7.8	×								
11	Voltage drop test	7.2				×	×	×	×	×	×
12	Operating time rating test	110% of rated current		×		×	×	×	×	×	×
		200% of rated current		2		2	2	2	2	2	2
		350% of rated current		2		2	2	2	2	2	2
		600% of rated current		2		2	2	2	2	2	2

**Remark:** For the test sample groups marked with X, use six fuse-links.

The colored part  shows the measurement after durability test.